

# STARLINE®

PROFESSIONAL WASH SYSTEMS

## GL

### Fully Insulated Premium Undercounter Glasswasher / Dishwasher – 435/450mm Rack

**W 535mm x D 560mm x H 835mm**

The GL is a fully featured compact machine with powerful upper and lower wash systems and assured final rinse with break tank.

#### Standard Features

- Thermal & acoustic insulation with smooth action sprung door
- 2.6 litres per cycle hot water consumption
- Up to 1000 glasses per hour / 500 plates per hour
- Assured final rinse – 316 grade stainless steel break tank and rinse booster pump
- Reverse osmosis compatible for spot free results
- Electronic controls with enhanced functionality
- Multi-cycle options – 1, 2 and 3 minute cycles with manual cycle mode, Ecopower, Soft Start, Self Cleaning cycle and QuikStart
- Service diagnostics
- Enhanced filtration with hot rinse retention and active waste removal
- Dual chemical injectors
- Drain pump
- Independent stainless steel upper and lower wash & rinse arms with removable cleaning caps
- 3/6kW rinse heating
- 350mm door clearance
- Suits 450mm maximum rack width, accepts 435mm
- QuikConnect
  - Water supply hose
  - Dual chemical injector lines
  - Drain pump outlet hose
  - 15 amp plugset
- Includes adjustable feet & rear rollers for easy removal when cleaning
- No commissioning required
- Easily installed on 15A single phase - or 25A single phase/ 15A 3 phase for fast cycle recovery

#### Includes:

- 1 x 0428001 - 450mm cup rack
- 1 x 0428002 - 450mm dish rack
- 1 x C660503 - cutlery container



## GL

### Fully Insulated Premium Undercounter Glasswasher / Dishwasher – 435/450mm Rack

Designed and manufactured by **WASHTECH®**

**ISO9001**  
All Starline products are designed and manufactured by Washtech using the internationally recognised ISO9001 quality management system, covering design, manufacture and final inspection, ensuring consistent high quality at all times.

In line with policy to continually develop and improve its products, Washtech reserves the right to change specifications and design without notice.

WASHTECH LTD

PO Box 90-548  
Auckland 1142

414 Rosebank Road  
Avondale  
Auckland 1026  
New Zealand

Phone 09 829 0930  
info@washtech.co.nz  
www.starline.co.nz

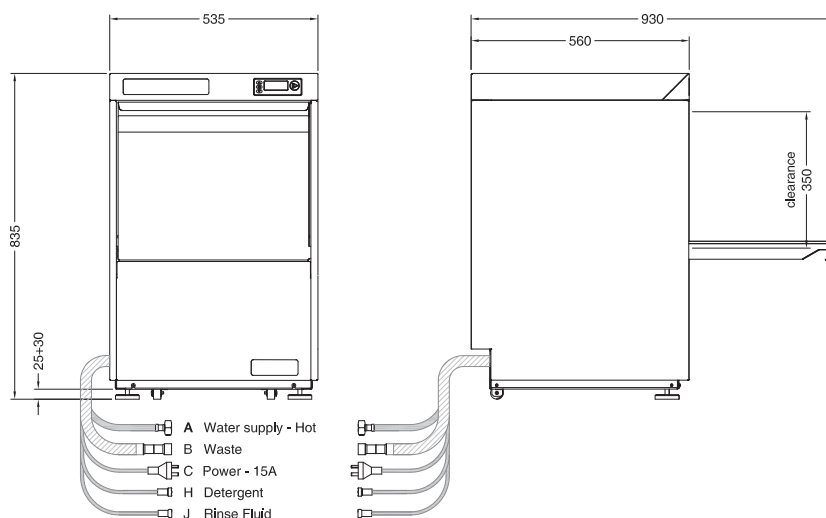

#### A Hot Water

temperature 65°C  
connection 3/4" male; hose supplied  
pressure 200-350kPa  
flow 15 litres per min  
quality potable & soft  
backflow prevention atmospheric vacuum breaker

#### B Waste

connection hose supplied for 38mm  
open standpipe 750 high or  
connection to sink trap

#### C Electrical

single phase 230V 50Hz 15 amp plugset supplied  
or single phase 230V 50Hz 25 amp  
or 3 phase 400V 50Hz 15 amp per phase

Refer operator manual for complete installation instructions

#### Dimensions

Width 535mm  
Depth 560mm  
Height 835mm  
Weight 66kg

#### Packed Dimensions

Width 645mm  
Depth 610mm  
Height 970mm  
Weight 77kg  
Cubicmetres 0.40m<sup>3</sup>



On call service where you are.

Washtech provides full service backup, 24 hours a day, 7 days a week with factory based technicians and a comprehensive nationwide network of independent service providers.

STARLINE SERVICE 09 829 0923