

TECHNICAL SPECIFICATION SHEET FOR

# Icematic CS ZP Ice Maker - Self Contained

## **CS28 ZP** Ice cubes 35mm x 37mm x H 32mm, 20g



### Ice Maker

- **25kg** daily production rate
- **6.5kg** storage bin capacity
- W 35mm x D 37mm x H 32mm, 20g ice cubes
- **18** ice cubes per cycle
- **2.3** litres per hour water consumption
- Air cooled condensing unit
- Zero Pollution (ZP) - uses R290 propane refrigerant gas
- Energy efficient - energy saving up to 25%
- Spray system technology to produce patented pure, clear and transparent ice cubes
- Electronic bin level sensor
- Multicolour LED button for machine status - standby, cleaning, and optional Ozone cycle
- Automatic Cleaning
- Easy access internal bin pan for easy clean

- Stainless steel external body
- Front ventilation for improved yield even in critical install
- Moffat TA13-NZ filter kit, including head and fittings

Note: Ice production rate is measured with the water temperature at 10°C and an ambient temperature of 21°C.

## TECHNICAL SPECIFICATION SHEET FOR

# Icematic CS ZP Ice Maker - Self Contained CS28 ZP



moffat.co.nz

New Zealand  
Moffat Limited

Christchurch  
45 Illinois Drive  
Rolleston  
Christchurch 7675  
Telephone 03-983 6600  
Facsimile 03-983 6660  
sales@moffat.co.nz

Auckland  
Telephone 09-574 3150  
sales@moffat.co.nz

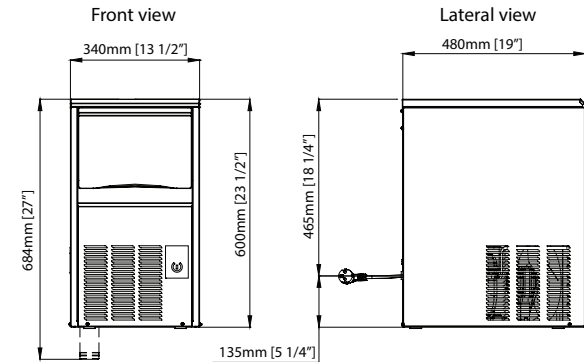

Kit 4 Feet Optional  
Ø50mm H100-120 mm

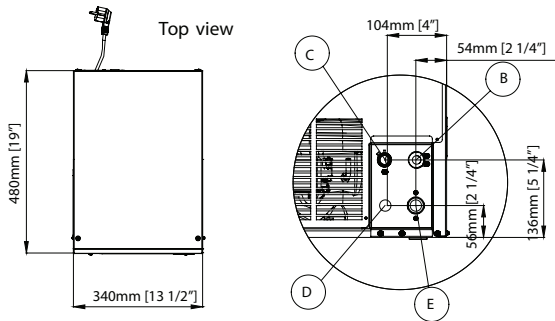

- B** Electrical cable supply /
- C** Water outlet connection 20mm
- D** Water outlet connection water condensation 20mm
- E** Water inlet connection - 3/4" gas

### Ice production per 24 hours

		Water temperature				
		32°	21°	15°	10°	
Ambient temperature	10°	20	24	26	28	kg
	21°	18	22	23	25	kg
	32°	15	19	20	22	kg
	38°	13	16	17	18	kg

## CS28 ZP

### Dimensions

Width: 340mm  
Height: 600mm  
Depth: 480mm  
Nett weight: 73kg  
Packed weight: 33kg

### Ice cube production dimension

Ice: 35mm x 37mm x H 32mm, 20g

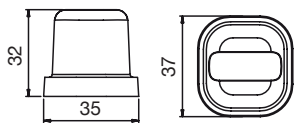

### Water consumption

Air cooled version:  
2.3 litres per hour

Air cooled version: 220-240V,  
1P+N+E, 50Hz  
Compressor power rating 653W  
Total absorbed power 300W,  
10A cordset fitted

Refrigerant type  
R290

### Installation distance from wall

- rear 150mm
- right 50mm
- left 150mm

Placement of unit should be indoors in an environment that does not exceed the air and water temperature limitations of the unit

### Water connection requirements

Inlet connection: R 3/4"  
Cold water (5-35°C)  
Pressure (1-5 bar)  
Water outlet connection: Ø 20mm

**Note:** 3m radius to any source of flame, combustion material or explosive material and ensure sufficient air circulation.

### Disclaimer:

All unit capacities are based on subjective testing. Moffat accepts no liability for production values.



In line with policy to continually develop and improve its products, Moffat Limited reserves the right to change specifications and design without notice.

© Copyright Moffat Ltd  
NZ.ICE.S.2201

